

# TRUCK STOPS & SHOPS

JANUARY  
2020

## TOOLS & EQUIPMENT PRODUCT GUIDE



*Wesbrooks, Inc.*

**Tool & Equipment Specialist**

**"We service what we sell"**

800.772.0863 • Fax: 940.723.4190 • Tel: 940.723.4181  
Email: [tools@wesbrooksinc.com](mailto:tools@wesbrooksinc.com) • [www.wesbrooksinc.com](http://www.wesbrooksinc.com)  
2012 Sheppard Access Rd. • Wichita Falls, TX 76306

# When your . . .

• Impact stops Impacting • Jack stops Jacking • Pump stops Pumping

## Exchange Tools

Cores must be practical to repair. Additional charges will be added for major damaged parts or missing parts needed. 90-Day Limited Warranty – FOB: Wichita Falls, TX

### CHICAGO PNEUMATIC



CP-797-6 & CP7778-6 1" Drive	\$295.
CP-797SP-6 / CP7778SP-6 Spline Drive	\$330.
CP-772 & CP7763 3/4" Drive	\$202.

### INGERSOL RAND



285B-6 & 285A-6 1" Drive	\$295.
285BSP-6 & 285ASP-6 Spline Drive	\$330.
IR261 3/4" Drive	\$243.

### IMT BEAD BREAKER

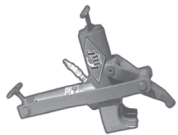

**\$375.**

### BLACKHAWK - IMT OTC - RAM PAC



**\$265.**

### FLOOR JACK EXCHANGE



POWER	UNIT	JACK
2 Ton F.J.	\$168.	\$220.
4 Ton F.J.	\$333.	\$502.
10 Ton F.J.	\$642.	\$899.
HD. Trans. J.	\$379.	\$628.

### TOOL EXCHANGE

- Looks Like NEW • Works Like NEW
- Guaranteed Like NEW



**1/2" Sq. \$89.**

### JACK EXCHANGE



**3-1/2" Ton OM-WB-27036 \$218.**



**Factory Trained Repairmen**

## Exchange Tools

Cores must be practical to repair. Additional charges will be added for major damaged parts or missing parts needed. 90-Day Limited Warranty – FOB: Wichita Falls, TX

### HEIN WERNER

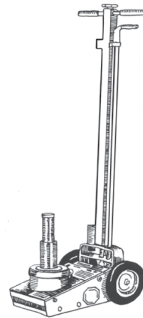

Gray-OTC 25 Ton • 8850-01002	\$866.
3" Ext. • 8850-01020	\$155.
New Power Unit	\$840.

### CHICAGO PNEUMATIC

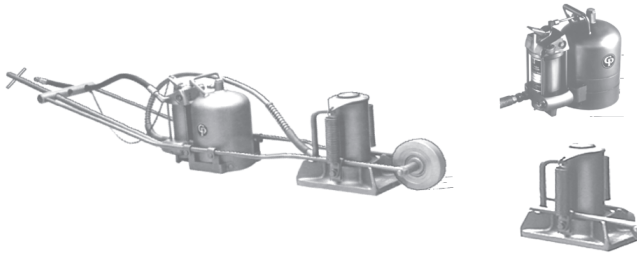

Complete Jack • CP-705-20TCS/50TC	\$604.
CP-705-16 Pump	\$368.
CP-20T/CP-50T Jack	\$368.

*When problem is isolated order only unit needed.*

### OIL METER EXCHANGE



Quarts • Pints • Gallons	\$163.
Grease Control	\$65.
Preset Countdown	\$262.

• Alemite • Aro • Balcrank • Graco • Lincoln • Sampson

### ELECTRONIC METER EXCHANGE



**GRACO**

EM5 Standard	\$244.
PM5 Countdown	\$352.

### JACK EXCHANGE SALE

**FACTORY RECONDITIONED**

- Looks Like NEW • Works Like NEW
- Guaranteed Like NEW



22-Ton Air/Hyd Service Jack Power Unit	\$387.
4" Ext. • 72204	\$35.
20 Ton • 18202C <small>Low: 9-1/2" • High: 18-5/8" • (Incl. 3" Ext) • wt. 35 lb.</small>	\$199.

### EXCHANGE OIL, GREASE, & DIAPHRAGM PUMPS

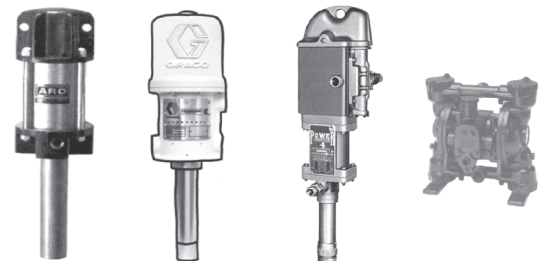

Alemite - Aro - Balcrank - Graco - Lincoln - Sampson

### Instructions...TOOL EXCHANGE

Shipping in Cores for Exchange

- Ship your core (wore out) to us by UPS.
- Be sure your return address is on the shipping carton and enclose your name, phone and instructions.
- When product is received and identified, we will ship the exchange ASAP.
- COD customers must ship in their cores first.
- OPEN account customers can order tool exchanges shipped out with core due.
- OPEN account customers must ship in cores immediately upon receipt of exchanges or be billed a core charge.

*Saving some money?...  
OEM parts instock and available.  
Order online*

# AIR IMPACT TOOLS



**Chicago  
Pneumatic**

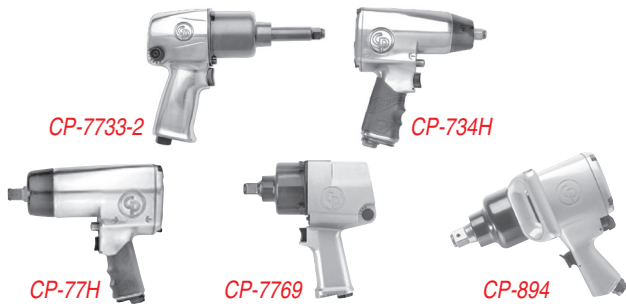

- CP-7733-2 • 1/2" Air Wrench • 550ft lbs
- CP-734H • 1/2" Air Wrench • 425ft lbs
- CP-772H • 3/4" Air Wrench • 1,000ft lbs
- CP-7769 • 3/4" Air Wrench • 1,080ft lbs *Heavy Duty*
- CP-894 • 1" Air Wrench • 1,700ft lbs *Heavy Duty*



- CP-789R26 • 3/8" Capacity Air Drill • 2600 RPM
- CP-789HR • 1/2" Capacity Air Drill • 500 RPM
- CP-711 • Air Hammer • Light Duty
- CP-7150 • Air Hammer • Medium Duty
- CP-714 • Air Hammer • Heavy Duty



- CP-854 • 4" Sander/Grinder
- CP-865S • 7" Sander/Grinder
- CP-860 • 1/4" Die Grinder • 24,000RPM *Heavy Duty*
- CP-873K • Low Speed Tire Buffer
- CP-828 • 3/8" Dr. Air Ratchet
- CP-282H • 1/2" Dr. Air Ratchet
- CP-710 • Engraving Pen (*with Engraving Stylus*)
- CA-156963 • Replacement Stylus



**Ingersoll Rand®**



IR-2115TI      IR-2135TI      IR-231HA      IR-261

- IR-2115TI MAX • 3/8" Air Wrench • 280ft lbs
- IR-2135TI MAX • 1/2" Air Wrench • 700ft lbs
- IR-231HA-2 • 1/2" Air Wrench • 580ft lbs
- IR-261 • 3/4" Air Wrench • 1100ft lbs



- IR-285B-6 • 1" Sq. • 1,400ft lbs
- IR-285B-S6 • #5 Spine
- IR-2850MAX-6 • 1" Sq. • 2,000ft lbs (*wt. 21.58lbs*)



**Chicago  
Pneumatic**



- CP-7782-6 • 1" Sq. • 1,850ft lbs
- CP-7782-SP6 • #5 Spine

**Sales - Service  
1 Year Warranty!**





# AIR TOOL ACCESSORIES - COMPRESSORS

## FILTERS • REGULATORS • LUBRICATORS



THREAD	FILTER	REGULATOR	LUBRICATOR
3/8	07F21A Manual Drain	06R215A w/Gauge	06L21B
3/8	07F25A Auto Drain	06R215A w/Gauge	06L21B
1/2	07F31A Manual Drain	07R315A w/Gauge	07L31B
1/2	07F35A Auto Drain	07R315A w/Gauge	07L31B
3/4	07F41A Manual Drain	07R415A w/Gauge	07L41B
3/4	07F45A Auto Drain	07R415A w/Gauge	07L41B
1	24-351 Manual Drain	24-451 w/Gauge	24-551
1	P3NFA98GSA Auto Drain	24-451 w/Gauge	24-551

## QUICK CHANGE COUPLERS

COUP SIZE	THREAD SIZE			
1/4	1/4	CA046300	CA046301	CA046302
3/8	1/4	CA047300	CA047302	CA047303
3/8	3/8	CA047301	CA047304	CA047305
1/2	1/4			1855
1/2	3/8	CA049300	CA049302	CA049303
1/2	1/2	CA049301	CA049304	CA049305

## AIR HOSE *Red Rubber • 1 Braid / 200psi*

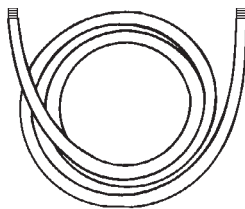

<b>3/8 x 24-1/4 npt • 3825R</b>
<b>3/8 x 50-1/4 npt • 3850R</b>
<b>1/2 x 25-1/2 npt • 1225</b>
<b>1/2 x 50-1/2 npt • 1250</b>

## AIR COMPRESSORS

**CHAMPION HONDA KOHLER**  
POWER EQUIPMENT

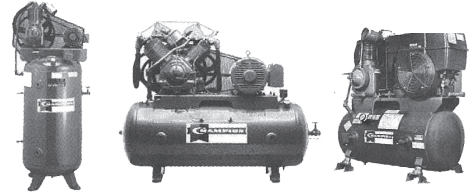

**Champion CASRSA01** - 5h.p. • 16.5 cfm @ 175 psi  
80gal. - w/ Mag Starter • 230 Volt 1 phase  
Low Oil Monitor • Auto Tank Drain • Vibro Isolators

**Champion CASRSA23** • 34.8 cfm @ 175 psi  
120gal. - w/ Mag Starter • 230 Volt 3 phase  
Low Oil Monitor • Air Cooled After Coolers  
Auto Drain Tank • Vibro Isolators

**Kohler HGR7-3**  
14h.p. • Gasoline • 30gal.  
23.2 cfm @ 175 psi

**Honda HGR7-3H Engine**  
13h.p. • Gasoline • 30gal.  
23.2 cfm @ 175 psi

## REPLACEMENT PUMPS

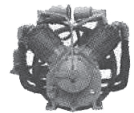

**R15B • 3 - 5 hp**

**R30D • 7-1/2 - 10 hp**

**R40A • 15 hp**

**R70A • 20 - 25 hp**

**Compressor Oil • GMP1 • 1 gal.**

**Compressor Oil • GMP5 • 5 gal.**

*Change Compressor Oil Every 3 Months • Spare Parts & Filters Available*

## PROTECTOR COVERS FOR C.P. TOOLS



PART #	FITS TOOL #
CA129405	CP-734/734H
231-BOOT	231/231HA
CA124745	CP-772/772H
CA139818	CP-797-6, CP-7640-6
285-P32	IR 285S-6
CA000046 • 1 Pint Air Tool Oil	
P089507 • 1 Gallon Air Tool Oil	
CA131898 • 14 oz. Cart. Grease	

# IMPACT SOCKETS - 1/2 • 3/4 • 1 • #5 SPLINE

## 1/2" DRIVE



SIZE	STD. NUMBER	DEEP NUMBER
3/8	2012R	2012D
7/16	2014R	2014D
1/2	2016R	2016D
9/16	2018R	2018D
5/8	2020R	2020D
11/16	2022R	2022D
3/4	2024R	2024D
13/16	2026R	2026D
7/8	2028R	2028D
15/16	2030R	2030D
1	2032R	2032D
1-1/16	2034R	2034D
1-1/8	2036R	2036D
1-3/16	2038R	2038D
1-1/4	2040R	2040D
<b>FLIP SOCKETS</b>		
13/16 X 3/4 • 2346D		
19 X 21mm • 2392D		
<b>ADAPTERS</b>		
1/2F X 3/8M • 2228A		
1/2F X 3/4M • 2238A		

## 3/4" DRIVE

SIZE	STD. NUMBER	DEEP NUMBER
11/16	2012R	2012D
3/4	2014R	2014D
7/8	2016R	2016D
15/16	2018R	2018D
1	2020R	2020D
1-1/16	2022R	2022D
1-1/8	2024R	2024D
1-1/4	2026R	2026D
1-1/2	2028R	2028D
27mm	2030R	2030D
30mm	2032R	2032D
33mm	2034R	2034D
35mm	2012R	2012D
41mm	2014R	2014D
<b>BUDD WHEEL (4 POINT)</b>		
13/16 sq • 3313S		
17mm sq • 3317S		
21mm sq • 3321S		
<b>COMBINATION (BUDD WHEEL)</b>		
13/16 X 1-1/2 • 3223C		
<b>THINWALL</b>		
1-1/16 • 3034DT		
1-1/8 • 3036DT		
1-1/4 • 3040DT		
<b>ADAPTERS</b>		
3/4F X 1/2M • 3008A		
1/2F X 3/4M • 2238A		
3/4F X 1M • 3009AB		

## 1" DRIVE

SIZE	STD. NUMBER	DEEP NUMBER
1-1/8	4036R	4036D
1-3/16	4038R	4038D
1-1/4	4040R	4040D
1-5/16	4042R	4042D
1-1/2	4048R	4048DB
1-3/4	4056R	4056D
27mm	4027M	4027MD
30mm	4030M	4030MD
33mm	4033M	4033MD
35mm	4035M	4035MD
41mm	4041M	4041MD
<b>BUDD WHEEL (4 POINT)</b>		
13/16sq • 4313S		
15/16sq • 4315S		
17mm sq • 4317S		
21mm sq • 4321S		
<b>COMBINATION (BUD WHEEL)</b>		
13/16 X 1-1/2 • 4223C		
<b>THINWALL</b>		
1-1/16 • 4034DT		
1-1/8 • 4036DT		
1-1/4 • 4040DT		
<b>ADAPTERS</b>		
1F X 3/4M • 4008AB		
1F X #5 spM • 4011A		

## #5 SPL. DRIVE

SIZE	STANDARD NUMBER
1	5032R
1-5/16	5042R
1-1/2	5048R
1-1/2	5048DB DEEP
1-3/4	5056R
27mm	5027M
30mm	5030M
33mm	5033M
33mm	5033MD DEEP
35mm	5035M
41mm	5041M
<b>BUDD WHEEL (4 POINT)</b>	
13/16sq • 5313S	
15/16sq • 5315S	
17mm sq • 5317S	
21mm sq • 5321S	
<b>COMBINATION (BUD WHEEL)</b>	
13/16 X 1-1/2 • 5223C	
<b>THINWALL</b>	
1-1/16 • 5034DT	
1-1/8 • 5036DT	
1-1/4 • 5040DT	

## #5 SPL. DRIVE

41mm • 5041MDT
<b>ADAPTERS</b>
#5spF X 3/4M • 5008A
#5spF X 1M • 5009AB

## SOCKET SETS

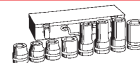

### 1/2" DRIVE

**STANDARD #1312 Grey - 13 Pc. S.A.E.**  
7/16, 1/2, 9/16, 5/8, 11/16, 3/4, 13/16, 7/8, 15/16, 1, 1-1/16, 1-1/8, 1-1/4

**STANDARD #1412M Grey - 14 Pc. Metric**  
10, 11, 12, 13, 14, 15, 16, 17, 18, 19, 21, 22, 26, 27mm

**DEEP #1312D Grey - 13 Pc. S.A.E.**  
7/16, 1/2, 9/16, 5/8, 11/16, 3/4, 13/16, 7/8, 15/16, 1, 1-1/16, 1-1/8, 1-1/4

**DEEP #1412MD Grey - 14 Pc. Metric**  
10, 11, 12, 13, 14, 15, 16, 17, 18, 19, 21, 22, 26, 27mm

### 3/4" DRIVE

**STANDARD #8034 Grey - 8 Pc. S.A.E.**  
1, 1-1/16, 1-1/8, 1-1/4, 1-5/16, 1-3/8, 1-7/16, 1-1/2

**DEEP #8034D Grey - 8 Pc. S.A.E.**  
1, 1-1/16, 1-1/8, 1-1/4, 1-5/16, 1-3/8, 1-7/16, 1-1/2

**STANDARD TRUCK TIRE #8030 Grey 9 Pc. S.A.E.:** 3/4, 7/8, 33mm, 1std, 1-1/16, 1-1/8, 1-1/4 TW, 1-1/2dp., 13/16sq.

**METRIC TRUCK TIRE #8133 Grey 11 Pc. Metric:** 17, 20, 21mm sq; 27, 30, 30, 32, 33, 35, 36, 38, 41mm dp

### 1" DRIVE

**STANDARD #9108 Grey - 8 Pc. S.A.E.**  
7/8, 15/16, 1, 1-1/16, 1-1/8, 1-3/16, 1-1/4, 1-1/2

**DEEP #9108D Grey - 8 Pc. S.A.E.**  
7/8, 15/16, 1, 1-1/16, 1-1/8, 1-3/16, 1-1/4, 1-1/2

**STANDARD TRUCK TIRE #9108D Grey 8 Pc. S.A.E.:** 7/8, 15/16, 1, 1-1/16, 1-1/8, 1-3/16, 1-1/4, 1-1/2

**METRIC TRUCK TIRE #9155 Grey 8 Pc. Metric:** 30, 33 std; 35, 38, 41mm dp; 17, 20, 21mm sq

### #5 Spl. Drive

**STANDARD TRUCK TIRE #9260 Grey 10 Pc. Spline:** 13/16sq, 7/8, 15/16, 1-3/16, 33mm std; 1-1/2dp; 1-1/16, 1-1/8, 1-1/4TW

# PULLERS • TORQUE • WRENCHES

## WHEEL BEARING LOCKNUT WRENCHES • O.T.C. 3/4" DR.

WRENCH NO.	OPENING SIZE
1901	2-3/32 • 6pt
1920	2-1/4 • 6pt
1902	2-3/8 • 6pt
**1936	2-3/8 • 6pt
1903	2-3/8 • 8pt
1921	2-1/2 • 6pt
1904	2-9/16 • 6pt
1905	2-9/16 • 6pt
**1928	2-9/16 • 8pt
1922	2-5/8 • 6pt
1923	2-3/4 • 6pt
1937	2-3/4 • 8pt
1932	2-7/8 • 6pt
193.3	2-7/8 • 8pt
1906	3 • 6pt
1907	3 • 8pt
1934	3-1/8 • 6pt
1935	3-1/8 • 8pt
1908	3-1/4 • 6pt
1909	3-1/4 • 8pt
1924	3-3/8 • 8pt
1910	3-1/2 • 6pt
1911	3-1/2 • 8pt
1925	3-3/4 • 8pt
1926	3-3/4 • 6pt
1927	3-13/16 • 8pt
1912	3-7/8 • 6pt
1913	3-7/8 • 8pt
1914	4 • 6pt
1915	4-1/8 • 6pt
1940	4-1/8 • 8pt
1916	4-3/8 • 6pt
1917	4-3/8 • 8pt
1938	4-1/2 • 8pt
1941	4-13/16 • 8pt
1918	4-7/8 • 6pt
1919	4-7/8 • 8pt
1939	5-1/4 • 6pt
1950M	54mm • 6pt
1951M	55mm • 6pt
1952M	60mm • 6pt
1953M	70mm • 6pt
1954M	71mm • 6pt
1955M	80mm • 6pt
1956M	82mm • 8pt
1957M	90mm • 8pt
1958M	94mm • 8pt
1959M	106mm • 8pt
1960M	110mm • 8pt
1961M	120mm • 8pt

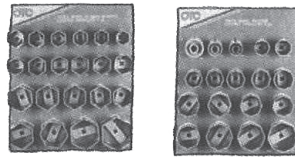

**9850 • O.T.C. Wheel Bearing Locknut Wrench**  
(6-pt Set with Board)

**62908** - Display Board Only

**9851 • O.T.C. Wheel Bearing Locknut Wrench**  
(8-pt Set with Board)

**62909** - Display Board Only

**TIREMAN II**  
TORQUE WRENCH™



with carrying case

- Accurate results to +/- 4%, even in harsh conditions
- The wrenches are accompanied by a calibration certification satisfying ISO 17025 requirements
- Accurately torques both right and left handed threads
- The break back action can be seen and felt
- Improved accuracy with the break angle reducing the possibility of over torquing
- Equally at home in the garage or on the service truck

**The wrench for the trucking industry!**

## PINION NUT 3/4 DR. SOCKET SET



8370

SOCKET NO.	OPENING SIZE
3764D	2" • 6pt
3768D	2-1/8" • 6pt
3772D	2-1/4" • 6pt
3776D	2-3/8" • 6pt
3780D	2-1/2" • 6pt
3784D	2-5/8" • 6pt
3788D	2-3/4" • 6pt

## ATD TORQUE WRENCHES



**101M** • 1/2" dr. (20-150 ft. lb.)

**102M** • 1/2" dr. (25-250 ft. lb.)

**109** • 3/4" dr. (100-600 ft. lb.)

## TIGER TOOL



Heavy Duty U-Joint Puller

**10102**

Disassembles even the most seized U-joints in minutes on virtually all Class 7 and 8 trucks and machinery.



Universal Pivot Pin Extractor

**10705**

Provides fast and effective removal of even the most seized pivot pins, found on a variety of equipment.



Heavy Duty Yoke Puller

**10803**

Simplifies and expedites the removal of heavy-duty yokes on driveshafts, transmissions and rear-end differentials.



Pin & Bushing Starter Kit

**15000**

Serves both rubber-isolated and threaded pins & bushings while the suspension remains on the vehicle.



BVA Hydraulic Pump w/ 12' Hose

**70130**

A more cost effective solution that delivers the performance and quality you expect from BVA.

## OTC TORQUE WRENCHES

**7377** • 1/2" dr. (30-150 ft. lb.)

**7378** • 1/2" dr. (50-250 ft. lb.)

**7379** • 3/4" dr. (100-600 ft. lb.)

## TIREMAN II WRENCHES

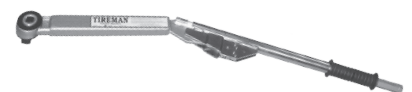

**TM-750** • 3/4" dr. (750 ft. lb.)

**TM-750-1** • 1" dr. (750 ft. lb.)

w/ case

# LIFTING EQUIPMENT

## FLOOR JACKS

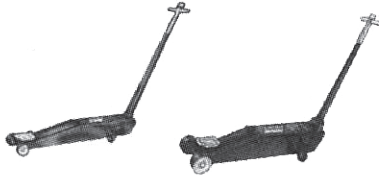

- 71335 • Norco 3.5 Ton
- 71500G • Norco 5 Ton
- 71000D • Norco 10 Ton
- 71100A • Norco 10 Ton w/ Air
- 72220A • Norco 20 Ton
- HW93657 • HW / Lincoln 4 Ton
- HW93660 • HW / Lincoln 10 Ton
- HW93662 • OPTION HW / Lincoln 10 Ton



- 10125C • 12 Ton
- 10129C • 12 Ton Short
- 10205C • 20 Ton
- 10209C • 20 Ton Short
- 10300 • 30 Ton
- 10500 • 50 Ton
- WB18204C • 20 Ton Air Hyd
- 18302 • 30 Ton Air Hyd
- 18502 • 50 Ton Air Hyd
- 18992 • 100 Ton Air Hyd

## TRANSMISSION JACK



- OM-41000 • 1,000 lb
- NR-72500E • 1,000 lb

## PALLET JACK



Model 151009 • 5,500lb cap • 27' x 48''

## SHOP PRESETS



60120 • 12 Ton



60200 • 20 Ton

## CRANES

- 44010 • 1 Ton FOLD UP
- 44020 • 2 Ton



## HOIST JACKS

- 5041B • 4 Ton Flat Mt.
- 5081B • 8 Ton Flat Mt.
- 5085 • Bottom Clevis Adapter



SPECIFICATIONS: Low Ht - 24-3/8"; Ext. Ht - 43-7/8"

## WHEEL DOLLY

- OM47053 • 3/4 Ton
- HW93765 • 3/4 Ton
- 10025C • 2 Ton Replacement Jack



## HYD. TRANSMISSION JACK

- 72000EI • Norco 3,000lb
- HW93718 • Hein Werner 2,000lb

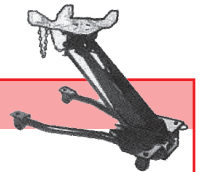

## PORTO POWER SETS

- 50040 • 4 Ton
- 50100 • 10 Ton



INCLUDES: Heavy duty storage case

## ENERPAC / OTC / POWER TEAM

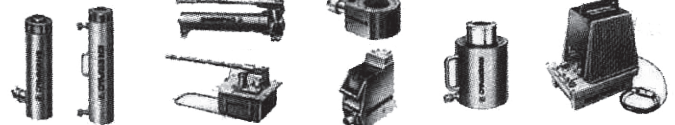

5 Ton thru 500 Ton

Catalogs Available



# LIFTING EQUIPMENT

## JACK STANDS



76320A



81225I



81208I / 81209I



82990C

**76320A • 20 Ton**  
Low: 10.88" High: 24.5" (Incl. 2.75" Ext.) wt: 41lb.

**81225I • 25 Ton Steering Axle**  
Low: 12" High: 20"

**32225B • Omega 22 Ton Steering Axle**

**81208I • 10 Ton**  
Low: 10-1/2" High: 17"

**81209I • 10 Ton**  
Low: 18-1/2" High: 30"

**81210I • 10 Ton**  
Low: 28" High: 47"

**82990C • 10 Ton**  
Min: 17.75" Max: 49.775"

**82992 • 15 Ton**  
Min: 18.125" Max: 51.375"



HW93506

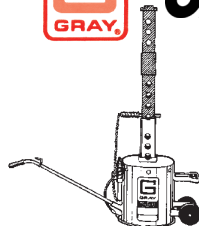

TAJS-2000



32125

**HW93506 • 6 Ton • 15-5/8" to 24-7/8"**

**32125 • Omega Heavy Duty 12 Ton • 17" to 27"**

**TAJS-2000 • Gray Truck Air Jack Stand • 10 Ton**

**TAJS-3000 • Gray Truck Air Jack Stand • 15 Ton**

Gray Truck Air Jack Stands: Min: 17-1/2" Max: 52-1/2"



**Chicago Pneumatic**



**CP-705-20TCS • 20 Ton**

**A092704NC • Ext. Block**

**CP-705-16H • A/H Pump**

**CP-705-50TC • 50 Ton**

## AIR HYDRAULIC JACK



**23222C • 22 Ton**

- Single Stage Axle Jack
- Quick Rated Capacity Lift
- Sturdy One Piece Handle
- Metered Release Valve

1 Year Guarantee



**72200D • 22 Ton**

- Includes 3/4", 2-1/4", & 4" Ext.
- Low Ht: 9"
- High Ht: 22"



**TSL-50 • 25 Ton**

- 3" Ext. Included
- Min: 8"
- Max: 21"

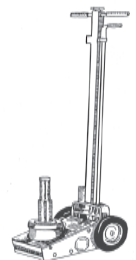

## SPECIAL JACK EXTENSIONS

**72203 • 2-1/4"**

**72204 • 4"**



# TIRE TOOLS • KENTOOL

## LOCK RING TOOLS



32123 • T-23 • 24"

33223 • T-23A • 30"

33224 • T-23B • 23-1/2"



32125 • T-25 • 18"

32127 • T-27 • 18"



32128 • T-27A • 18"

34648 • T-48A • 37"

## TUBELESS TIRE IRONS



34645 • T-45A • 37"

34747 • T-46A • 36"

34748 • T-47A • 52"

## TIRE CHANGING STAND

36015 • T115

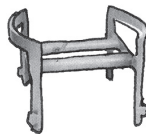

## SPOON TYPE IRONS



33219 • T-19A  
Straight



32120 • T-20  
Curved



32121 • T-21R  
Drop Center



30606 Kentool  
Chrome Lug Nut Pliers

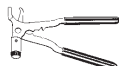

1470R Grey  
Weight Pliers



#CH5-TANK • Basic Unit

#2.106 • "Magnum" Barrel for CH5

## BUDD NUT TOOLS



30609 • TX-9

Hendrix 60300

## BEAD SEATER



BB9L • 9 Liter Bead Bazooka

## HAMMERS



35327 • T11D • Truck 17"

35127 • T11DH • Repl. Handle

35329 • T11E • Truck 30" HD

35129 • T11EH • Repl. Handle

35429 • TG11E • 30" Fiberglass Hdl.

35229 • TG11EH • Repl. Handle

35325 • T36 • 16-1/2" Handle

35119 • T11CH • Repl. Handle

35105 • Repl. Rubber Head

35926 • T26B • Slide Hammer Bead Breaker

## STUD REMOVERS / INSTALLERS



#X10-LT20B • 13/16sq. hd. • Stud Removal Kit

#X10-LN18B • Replacement Nut

#X10-S158B • 5/8" • Stud Installer

#X10-S134B • 3/4" • Stud Installer

## INFLATION CAGES

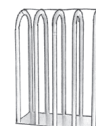

EZ Tire Rotator®



36001 • 2 Bar Portable • 3" x 21-1/2"  
Base Plate - 50" high Tire Size to 12 x 24 • T101

36007 • 2 Bar Portable for Super Singles

36002 • 4 Bar Cage • 26-1/2"  
Front Rear 17-1/2" wide x 55-1/2" high • T-102

36005 • 5 Bar Cage • 34-1/2"  
Front Rear 16" wide x 55" high • T-105

36014 • EZ Tire Rotator • Fits 3,4,5 Inflation Cages

Haltec High Volume Automatic Tire Inflator

# TIRE TOOLS & EQUIPMENT

## I.M.T. BEAD BREAKERS



IMT 51705747 • Air Hydraulic Pump w/ Hose • 5 Quart

IMT 79075107 • Model 210 • For Truck & Tractor Tires

IMT 51704499 • 55 Ton Aluminum Jack w/ High Pressure Valve  
• 6" Stroke • 12" Low Height • 7" x 7" Base Plate • Wt: 30lb.

IMT 51704331 • Model 1800 • For Off-the Road Tires  
Use with 25" to 51" dia. tires

## AIR / HYDRAULIC PUMP



910130 • Metal Reservoir • 122cu. in. Oil Cap  
Includes 10,000 psi gauge

B65594 • 6ft. Hose Only

4J120 • 10ft. Hose Only

## HYDRAULIC CYLINDERS



H1002 • 10 Ton BVA • 2" Stroke

H1006 • 10 Ton BVA • 6" Stroke

H1010 • 10 Ton BVA • 10-1/8" Stroke

*Industrial Quality*

## GAITHER SUPER "SLICK-EM"



12904-1GAL • 1 Gallon

12904 • Case (4-1 Gal.)

Model 2000 • Super Shot Sprayer • Red Steel  
Refillable • Reusable • Pressurized by Free Air

## TIRE TOOL STAND



Heavy Duty • Room For: Impact - Tire Trans &  
Hammers - Sockets - Bead Bazooka - Cheetah - Buffer

## BEAD SEATING SYSTEM



153-210 • Inflat. Ring

31-701 • Inflat. Tank

31-103 • Inflat. Hose w/ Valve

#ALL-3 • SPECIAL ALL 3

31-401 • 1" Ball Valve

31-303 • 8' Hose

## GAITHER BEAD SEATING SET



12886 • Lever Bar

12893 • Wedge

12894 • Beadkeeper

12897 • Clevis Bold (PR.)

12899 • Beavertail

12901 • Beaver Roller (PR.)

12902 • Standard Clevis

12903 • Clevis Roller (PR.)

12880 • 7 Pc. Set

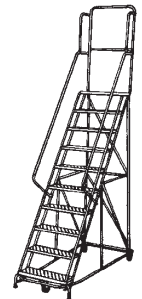

Call for our new  
Maintenance & Equipment Catalog  
800.722.0863



*Wesbrooks, Inc.*

Tool & Equipment Specialist

"We service what we sell"

# TIRE TOOLS & EQUIPMENT

## NEW PRODUCTS



**TM750 • 3/4" • 750ft/lbs Torque Wrench w/ case**

**TM750-1 • 1" • 750ft/lbs Torque Wrench w/ case**

**MC343413 • 3/4" x 3/4" x 13" Extension**

**MC34113 • 3/4" x 1" x 13" Extension**

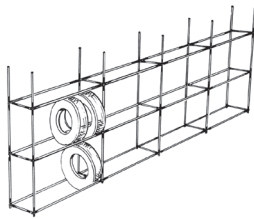
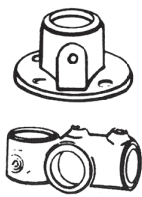

**RPN 2000 • "The Leg Extender" Tire Platform**

- Service Engine • Clean Windshield • Clean Ferring
- Ideal for fuel islands • Fits 22.5 - 24.5 tires

**62-8 • Kee Klamp • 1-1/2" Floor Fange**

**46-8 • Kee Klamp • 1-1/2" Combo Tee**

*Also Available in 2" Pipe*

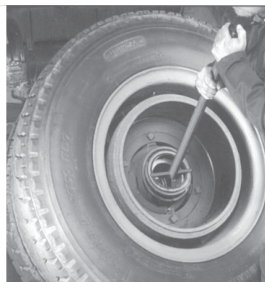

**TLN777 • "The Back Saver" Tire Lift**

- Lifts truck wheels
- Can rotate wheel on bearing rollers to lift for aligning studs
- Saves Time & Labor
- Will not damage studs • wt: 16lbs

**TNL 11 • Replacement Wheel Assy.**

**SRT-1 • Chicago Rawhide Wheel Seal Puller**

- Heavy Duty
- Saves Bearings
- Saves Time
- Easy to Use
- Works with Steer, Drive, Trailer Seals

**No More Back Strain  
Reduce Claims & Liability**

## TIRE SPREADER



**Brannick 5300**

- Bead width up to 16"
- Bead Diameter up to 24.5"
- Max Capacity 200lbs

## WHEEL CHOCKS



**WC888B-2 Pair • Durable**

- Contured to fit tire
- Connected by 4' Chain
- Extra Heavy Duty

## TRUCK WHEEL NUT TORQUE TEST



**16600 Mountain • 3/4 dr.**

**6020AB Proto • 3/4 dr.**

**3010EB • 3/4dr. X 10" Ext.**

**100 - 600 ft. lb.**

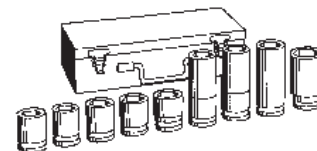

**8030 Grey • 9 Pc. S.A.E.**

- Consists of:
  - 3/4, 7/8, 33mm, 1 std
  - 1-1/16, 1-1/8, 1-1/4TW, 1-1/2 dp.
  - 13/16 sq.

# TIRE TOOLS & EQUIPMENT

## COATS ELECTRONIC TRUCK WHEEL BALANCER

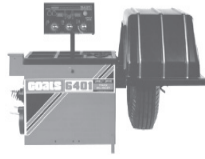

6450 • 1 & 3 Phase Available

## ACCESSORIES FOR 6450 TRUCK TIRE BALANCER

143935 • Large Budd Wheel Adapter

109877 • Hub Centered Truck Cone Kit

### REPLACEMENT PARTS

309625 • Wing Nuts for 143935 Adapter (5 per adapter)

301609 • Threaded Studs for 143935 Adapter (5 per adapter)

309608 • Caliper

## ROTARY ELECTRONIC TRUCK WHEEL BALANCER



R544 • 110V / 1 ph • Rim Diameter 10" - 30"  
Rim Width 1.5" - 22"

## TIRE BUFFERS & ACCESSORIES



CP-873K • 1/4 collet chuck • 2,500 rpm

SLP-6520L • LIGHTED • 1/4 collet chuck  
• 2,250 rpm

107 • Rubberhog Tire Buffer • 2-1/2" Diameter  
• 3/8" Bore • Fine Coating

## TIRE & TUBE MOUNTING COMPOUND



#2005 • Murphey's • 25lb. Pail

## TUBELESS TRUCK TIRE TOOL SET

CALL FOR VIDEO DEMO!



TNT-100 • Set

TNT-100-1 • Demount Tool Only

TNT-200M • Mounting Tool Only

TNT-200-1 • Super Single Mount

TNT-100-8 • Demount Roll Pin

TNT-100-9 • Demount Tire Roller

TNT-100-10 • Main Roller

TNT-100-11 • Main Roll Pin

TNT-100-16 • Rear Mount Roller

TNT-100-18 • Rear Mount Roll Pin

TNT-100-19 • Mount Roll Pin

TNT-100-20 • Mount Roller

Demounts in 8 sec. • Remounts in 20 sec.  
• No need to lift tire and rim to remove rear bead. Demounts both bead from same side of rim in seconds.  
• Will not damage beads and saves casings for retreading.  
• Demount and mount tires without removing wheel from vehicle.  
• Demounts/Mounts tires 17-1/2" to 24-1/2"  
• Use on all tubeless truck tires including single/duplex tires, radial and bias. Use on Dayton type wheels (centerless) and Budd type disc wheels.

## TIRE CHANGERS



#5060A • Air Motor

#5060E • Elect. Motor

## CHAMPION AIR COMPRESSORS



CASRSA23 • 10 h.p. • 34.8 cfm @ 175 psi • 120 gal - w/Mag. Starter • 30 Volt 3 Phase • Low Oil Monitor • Vibro Isolators, Auto Tank Drain, After Cooler

CADRSA54 • 10 h.p. • 69.6 cfm @ 175 psi • 250 gal - w/Mag. Starter Alternator • Low Oil Monitor • Vibro Isolators, Auto Tank Drain, After Cooler • 230 Volt 3 Phase

HGR7-3K • 13 h.p. • 23.2 cfm @ 175 psi • Gasoline - 30 Gal.

# TECHNICIAN TOOL SET

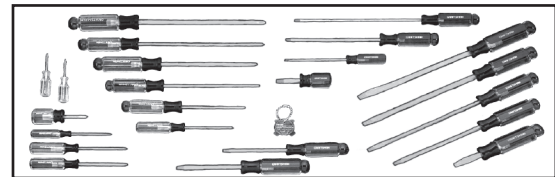
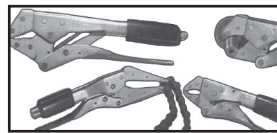
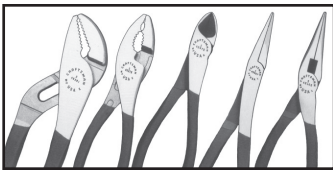
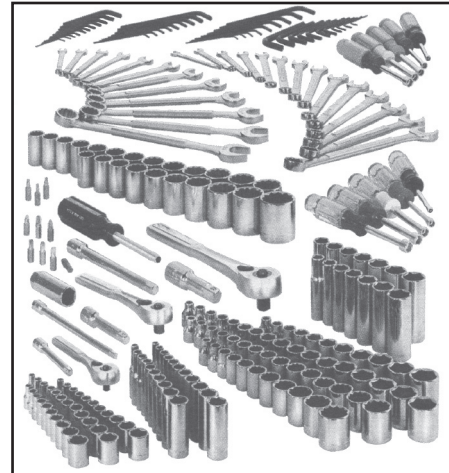

## TA-111 • Complete Technician Tool Set • Each Set Consists of:

5-Drawer Roll-Away Tool Box • 26-1/2W x 18D x 31-1/4H

232 Piece Tool Set

5 Piece Plier Set

RoboGrip Pliers • 9" Curved Jaw

24-oz. Ball Pein • 15-1/4" Hammer

12-oz. Plastic Tip • 12-1/2" Hammer

10 Piece Screw Extractor & Drill Bit Set

4 Piece Locking Plier Set

24 Piece Screwdriver Set



# LUBE EQUIPMENT - LINCOLN

## GREASE PUMPS



989 • 35lb
82716 • 35lb • Pump Only
917 • 120lb
917-57 • 120lb • with base
82050 • 120lb • Pump Only
82054 • 400lb • 50:1 80cu. in. • Pump Only
83366 • Follower Plate for 82054
81523 • Drum Cover for 82054
926 • 400lb • 50:1 80cu. in. • w/ drum cover, air coupler & nippler, 3ft air conn. hose, & 4ft grease conn. hose
1910-2 • 400lb • 50:1 460cu. in. • w/ drum cover
1935-2 • 400lb • 50:1 100cu. in. • w/ drum cover
83369 • Follower for 1910-2 & 1935-2

## OIL PUMPS



2435 • 120lb • w/ Pint Meter
282396 • 120lb Oil • Pump Only
535 • 120lb • w/ Pint Meter
613 • 120lb • Waste Oil Drain
1326 • Piston • 16-55gal • w/ bung bush
G402 • Rotary • 16-55gal • w/ bug bush
282398 • 3:1
84934 • 5:1
ACCESS. FOR 3:1 & 5:1 STUB PUMPS
845358 • Bung Bushing
84946 • 1" Low Level Cutoff
85765 • 1" Foot Valve
84945 • Suction Kit
84940 • Wall Mount Kit
1253 • Manual Bulk Oil • 30lb Container • w/ 2870 Pint Meter

## ROLLING DRAIN PAN



84700 • Axles adjust to fit pit widths of 36" to 49-1/2" • Holds up to 30 gallons of waste oil

## GREASE DRUM COVERS



46007 • 120lb
81523 • 400lb
84775 • 25-50lb • Pump Tube Size 1, 1-1/4, 1-1/2
84780 • 120lb • Pump Tube Size 1, 1-1/4, 2-1/8
83367 • 400lb • Pump Tube Size 1, 1-1/4, 1-1/2

## OIL PUMPS



83120 • Bung Bush
282133 • 55gal • 3:1 3 gpm
1293 • 35lb Manual Gear Lube w/ Clamp on Lid
240006 Wesco Drum Truck • For 55gal drum • Dispenses into 5gal can - no cradle needed • Self standing with kickstand
1931-1 • 55gal • 4:1 6.5 gpm w. Bung Bush
1901-1 • 55gal Oil • 12:1 -12gpm w/ Bung Bush
1940 • Bulk Oil Stub Pump • 4:1 6.5gpm
84164 • Stub Pump Wall Mount Kit
1914 • Bulk Oil Stub Pump • 12:1 12gpm

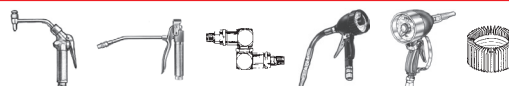

780 • Oil Control
740 • Grease Control
#82157 • 740 Replacement Kit
740 PARTS
5845 • Std. Gr. Coup.   5812 • 12" flex hose
5852 • Small Gr. Coup.   5818 • 18" flex hose
62028 • Ridgid Ext.   5861 • 36" flex hose
UNIVERSAL "Z" SWIVELS
81387 • 1/4 npt x 1/2-27 • for 740 Grease
83594 • 1/4 npt x 1/4 npt • for 740 Grease
82073 • 1/2 npt x 1/2 npt • for Oil Meters
OIL METERS
867 • Gal. Oil Meter
877 • Quart Oil Meter
878 • Pint Oil Meter
93547 • Nozzle
90464 • Swivel
91241 • 12" flex hose • 877/867
3867 • Preset Countdown Oil Meter • Quart
3868 • Preset Countdown Oil Meter • Gallon
93548 • Ridgid Nozzle
59628-001 • Oil Meter Shroud Protector

## DIAPHRAGM PUMP



85627 • Oil Transfer, Waste Oil Evac., Diesel, Gasolin & Antifreeze • 1" Inlet - Outlet

**OBORG® Filter Crushers**



P200L  
Truck Oil Filter  
Crusher

# LUBE EQUIPMENT - GRACO

## ELECTRONIC METER



**SDM8** • Dispenses at 5 gpm (18.5l/min) for fast filling • All meters will dispense in all units of measure: pints, quarts, gallons, & liters

## PRESET ELECTRONIC METER



**SDP18 Automatic Shutoff** • Dispenses at 5 gpm (18.5l/min) for fast filling • All meters will dispense in all units of measure: pints, quarts, gallons, & liters

## GREASE PUMPS

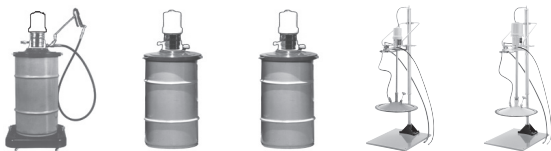

- 225-006 • FIRE-BALL • 120lb • 50:1 • 2.2lbs/min
- 239-887 • Pump Only
- 204-574 • Drum Cover
- 220-654 • Follower Plate
- 225-016 • FIRE-BALL • 400lb • 50:1 • 2.2lbs/min
- 239-888 • Pump Only
- 200-326 • Drum Cover
- 24F-903 • Follower Plate
- 225-016 • PRESIDENT • 400lb • 50:1 • 11lbs/min
- 205-395 • Pump Only
- 200-326 • Drum Cover
- 223-846 • Follower Plate
- 226-013 • FIRE-BALL Air Lift System • 400lb • 50:1
- 226-018 • PRESIDENT Air Lift System • 400lb • 50:1

## OIL CONTROLS



- 247-712 • w/ Rigid 30 Angle • Stem & Non Drip Nozzle
- 247-713 • w/ 10" Flex Hose & Non Drip Nozzle
- 247-714 • w/ Rigid Stem & Right Angle Non Drip Nozzle

## GREASE CONTROL



242-056 • Grease Control

### ADDITIONAL 242-056 PARTS

- 200-325 • Taper Nose Grease Coupler
- 204-204 • 12" Flex Hose w/ Gr. Coupl.
- 109-148 • 30" Flex Hose less Coupl.
- 243-446 • Repair Kit

### STRAIGHT SWIVEL

204-084 • 1/4 npt M x 1/4 npt F

### UNIVERSAL "Z" SWIVELS

- 202-577 • 1/4 npt M x 1/4 npt F
- 224-569 • 3/8 npt M x 3/8 npt F

## OIL PUMPS



- 203-876 • FIRE-BALL • 5:1 Stub Pump 11 gpm
- 205-626 • PRESIDENT • 10:1 Stub Pump 12 gpm
- 225-640 • 55 gal • 5:1 11 gpm
- 225-728 • 120lb Oil • 11 gpm
- 225-376 • Manual • 120lb Gear Oil
- ACCESS. FOR OIL STUB PUMPS**
- 222-308 • Bung Bushing
- 203-987 • Wall Mt. Bracket
- 236-054 • Suction Kit
- 203-688 • Low Level Cutoff

## FILTERS • REGULATORS • LUBRICATORS



Thread	Filter	Regulator	Lubricator
1/4	06F11A Manual Drain	06R115A w/ Gauge	06L11B
	06F15A Auto Drain		
1/2	06F11A Manual Drain	07R315A w/ Gauge	07L31B
	06F15A Auto Drain		



# LUBE EQUIPMENT - GRACO

## ROLLING DRAIN PAN



**235-346** • Fits track widths from 34.2 - 42.2in

**218-969** • Fits track widths from 39 - 46in

30 Gal. Tank Capacity • 1-1/2" Drain Valve, Quick Coupler & Coupler Cap



**226-289** • 35lb Manual Gear Lube

**225-272** • Telescoping Drain • 47" to 68"

**239-302** • 120lb Waste Oil Drain

**110-201** • Suction Gun

**108-458** • Ball Valve 1/2" npt

## GREASE ADAPTERS



**201-881** • Push Adapter

**205-532** • Steel Needle Adapter

**205-582** • Nylon Needle Adapter

**223-187** • 90° K-Car Adapt

## OIL FILTER DRAIN TABLE



**FDT**

72"L x 24"W x 38"H • 1" • Room to hang filter wrenches  
• Extra Heavy Duty

## DIAPHRAGM PUMPS



**647-016** • 1"

U.L. Approved • Unleaded Gas • Leaded Gas • Diesel Fuel • Kerosene • Aviation Fuel • Ethanol • Methanol

## DIAPHRAGM PUMPS

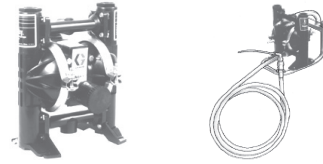

**241-906** • 3/4"

Antifreeze • Windshield Wash • Water

**223-695** • 3/4"

Oil Evac Pump w/ 10ft Suct. Hose & 4 Wands  
(3/16, 1/4, 3/8, & 1/2)

**241906** • Pump Only

## HOSE REELS



**HPH-55B** • Grease Hose • 3/8 id x 50ft

**HPH-23B** • Grease Hose • 3/8 id x 35ft

**HPH-15B** • Grease Hose • 1/4 id x 50ft

**HPM-33B** • Oil Hose • 1/2 id x 35ft

**HPM-65B** • Oil Hose • 1/2 id x 50ft

**HPL-23B** • Air / Water Hose • 3/8 id x 35ft

**HPL-56B** • Air / Water Hose • 3/8 id x 65ft

**HPL-65B** • Air / Water Hose • 1/2 id x 50ft

## REPLACEMENT HOSES

**124-461** • Grease Hose • 1/4 id x 20ft x 3/8 npt

**124-470** • Grease Hose • 1/4 id x 35ft x 3/8 npt

**109-158** • Grease Hose • 1/4 id x 50ft x 3/8 npt

**253-857** • Oil Hose • 1/2 id x 35ft x 1/2 npt

**256-864** • Oil Hose • 1/2 id x 50ft x 1/2 npt

**253-848** • Air/Water Hose • 3/8 id x 40ft x 1/2 npt

**253-850** • Air/Water Hose • 3/8 id x 60ft x 1/2 npt

**253-853** • Air/Water Hose • 1/2 id x 25ft x 1/2 npt

## HOSE REEL BALL STOPS



**222-225** • For 1/4 Grease Hose

**218-341** • For 3/8 & 1/2 Oil & Air/Water Hose

# LUBRICATION SYSTEMS

## REELS



- 94532 • Grease Reel • 1/4 id x 30ft
- 85006-30B • Grease Reel • 3/8 id x 30ft (HD)
- 94552 • Grease Reel • 1/4 id x 50ft
- 94334 • Oil Reel • 1/2 id x 30ft
- 83463-30 • Oil Reel • 1/2 id x 30ft (HD)
- 94354 • Oil Reel • 1/2 id x 50ft
- 94133 • Air/Water Reel • 3/8 id x 30ft
- 94132 • Air/Water Reel • 1/4 id x 30ft
- 94153 • Air/Water Reel • 3/8 id x 50ft



- D8630-OHP • Grease Reel • 3/8 id x 30ft
- D8440-OHP • Grease Reel • 1/4 id x 40ft
- D8450-OHP • Grease Reel • 1/4 id x 50ft
- D8830-OMP • Oil Reel • 1/2 id x 30ft
- D8840-OMP • Oil Reel • 1/2 id x 40ft
- 7850-OMP • Oil Reel • 1/2 id x 50ft
- 4625-OLP • Air/Water Reel • 3/8 id x 25ft
- 7650-OLP • Air/Water Reel • 3/8 id x 50ft
- 7850-OLP • Air/Water Reel • 1/2 id x 50ft

## REPLACEMENT HOSES



- 75240 • Grease Hose • 1/4 id x 20ft x 1/2-27
- 75360 • Grease Hose • 1/4 id x 30ft x 1/2-27
- 75480 • Grease Hose • 1/4 id x 40ft x 1/2-27
- 75600 • Grease Hose • 1/4 id x 50ft x 1/2-27
- 73240 • Oil Hose • 1/2 id x 20ft x 1/2 npt
- 73360 • Oil Hose • 1/2 id x 30ft x 1/2 npt
- 73480 • Oil Hose • 1/2 id x 40ft x 1/2 npt
- 73600 • Oil Hose • 1/2 id x 50ft x 1/2 npt
- 3825R • Air/Water Reel • 3/8 id x 25ft x 3/8 npt
- 72360A • Air/Water Reel • 3/8 id x 30ft x 3/8 npt
- 72480A • Air/Water Reel • 3/8 id x 40ft x 3/8 npt
- 72600A • Air/Water Reel • 3/8 id x 50ft x 3/8 npt

## HOSE BALL STOPS



- 85515 • For 5/8 OD Hose
- 85516 • for 5/8 - 3/4 OD Hose
- 85517 • for 3/4 - 1 OD Hose

## FUEL ISLAND REELS - ACCESSORIES - SPARE PARTS

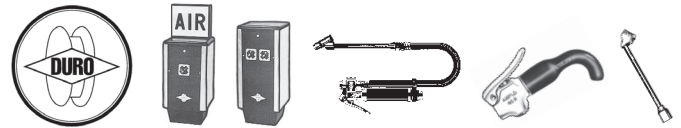

- Model 50-31 • Double Reel Unit w/ 30ft Hose (less water bibb & gauge)
- #SH-425-U • Repl. Hose (1/4 x 30ft)
- DUN101 • Tire Gauge 12" Hose & Swivel dual foot chuck (10-120 psi in 2 psi increments)
- I4059LOM • w/ 8ft Hose
- DUN40-R • Radiator Faucet w/ Rubber spout - 1/4 npt
- MSN-6999-L • Dual Lock-On Air Chuck 6" Long • 1/4" npt fem. thread

## DESIGN • LAYOUT • SELECTION

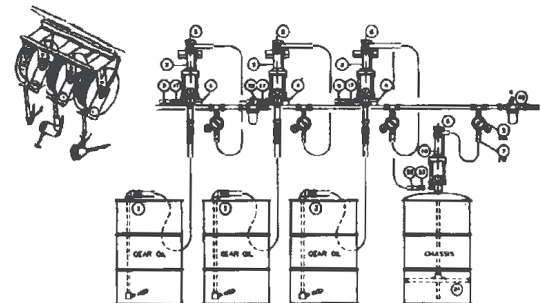
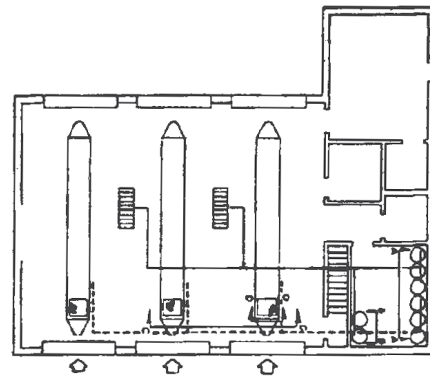

**WE CAN HELP YOU!**

**LEASE -PURCHASE PLAN**

# TRUCK & DIESEL SHOP EQUIPMENT

## BATTERY CHARGERS

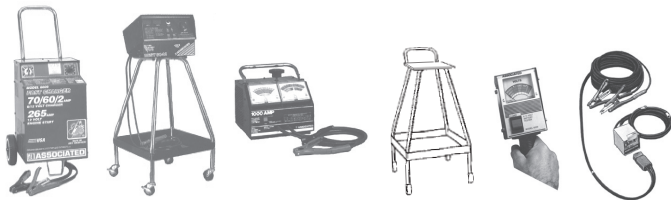

- 6012 • 6/12 Volt • 70/60 Amp • 250 Amp Boost
- 6009 • 6/12 Volt • 80/70 Amp • 420 Amp Boost
- 6006 • 6/12/24 Volt • 75/65/30 Amp • 455 Amp Boost
- 6042 • 500 Amp • Battery/Elec. • System Tester
- 6036B • 1,000 Amp • Load Tester
- 6038 • Tester Cart for 6036B
- 6029 • 125 Amp • Hand Held Load Tester  
(for 6/12 Volt Batteries, Starters, Alternators  
on all Vehicles.
- 6139 • Plug in Starter System • 25ft. Cables

## LOAD & ELECTRIC SYSTEM TESTER



**Auto Meter**  
TEST EQUIPMENT

- BVA-2100 • 800 Amp
- AC-14 • Internal Printer
- ES-5 • Stand
- IC-1 • Inductive Clamp

## HEAVY TRUCK STARTER & CHARGER



**K&K**  
Jump StartChargers, Inc.

- HT1224 • 12 & 24 Volt • Auto 10 Amp Charger
- 1400 Cranking Amps • 10ft Jumper Cables
- Ships with (2) Group 31 Batteries

## OIL FILTER PLIERS



- 50950 • Lisle • 3-5/8" to 6" Range

## OIL FILTER WRENCHES



- 70-761 • Plews 1/2" Drive • 4-1/8" to 4-21/32"
- 70-763 • Plews 1/2" Drive • 4-21/32" to 5-5/32"
- 70-765 • Plews 1/2" Drive • 5-5/32" to 5-21/32"

## AUTO METER



- BCT200-J • 6/12/24 Hand Held Tester
- BUS PRO-6005 • 6 multi station charger • 115v

## TIRE PLATFORM

"THE LEG EXTENDER"



- RPN 2000
- Service engine • Clean windshield • Clean Ferring
- Ideal for fuel islands • Fits 22.5 - 24.5 Tires

## BRAKE DRUM HANDLER

**norco**  
PROFESSIONAL LIFTING EQUIPMENT



- 72040A
- Handles 15" and 16-1/2" Drums • Only brake drum  
handler for both Outboard and Inboard drums
- Made in the U.S.A. • Wt. 58lbs

## BENCH VISES GRINDERS • WILTON • BALDOR



- 745 • 5" Bench Vise
- 746 • 6" Bench Vise
- 577101 • 6" Bench Grinder
- 712 • 7" Bench Grinder
- 812RE • 8" Bench Grinder

**AIR CONDITIONING EQUIPMENT**



**34288NI • Recovery Recycling Recharging Station • For R-134a w/ 1-30lb tank (oil injector not included)**

**34788 • Recovery Recycling Recharging Station • For R-134a w/ 1-30lb tank**

**15600 • Vacuum Pump • 6 CFM**

**16910 • Refrigerant Identifier • For R-12 & R-134a**

**16600 • Electronic Leak Detector • For all CFC, HCFC, & HFC Refrigerants**

**JENNY PRESSURE WASHER**



**E-1000-C**

- Pressure Wash - Pressure 1250 PSI
- Pressure Wash - Volume 2.3 GPM
- Pressure Wash - Temperature Up to 200°F
- Steam Cleaner - Pressure 100-200 PSI
- Steam Cleaner - Volume 40 GPH
- Steam Cleaner - Temperature 325°F
- Electronic Motor Horsepower 2.0

**WELDING EQUIPMENT**

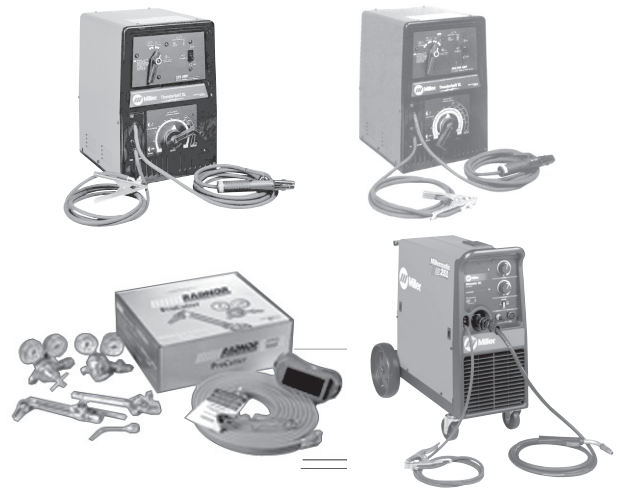

**907335 • Millermatic 90 Amp MIG Welder**  
120 Volt w/ Cables, Ground Clamp, Elect. Holder, Face Shield, Power Cord, Instructions

**903642 • Miller Thunderbolt 225 Amp AC/DC Stick Welder** • 230 Volt, 1 Ph. w/ Cables, Ground Clamp, Elect. Holder, Power Cord, Instructions

**64003004 • Radnor Welding / Cutting Kit**  
• w/ Torch, Tips, Cutting Assy., Oxy. & Acetyl, Regulators, 20ft Hose, Goggles, Lighter

**907321 • Millermatic 252 Amp Gas / Gasless MIG Welder** • 230 Volt, 1 Ph. w/ Gun, Regulator, Wire, Tips, Nozzle, Running Gear, Ground Cable & Clamp, Manual

**PARTS WASHER**



**55061-01 • Fountain • 30 Gallon w/ Stand**



# PRODUCT & MANUFACTURER'S GUIDE

New Products • Parts • Repairs

## AIR & ELECTRIC TOOLS

Astro	Makita
Black & Decker	Milwaukee
Chicago Pneum	National Detroit
Ingersol Rand	Sioux
Jet	St. Louis
Kett	

## AIR COMPRESSORS

Champion	IMT
Dayton	Ingersol Rand
Quincy	Kellogg

## AIR CONDITIONING TOOLS

Robinair

## AIR/HYD PUMPS

Blackhawk	NORCO
Chicago Pneum	OTC
Enerpac	Power Team
IMT	Ram Pac

## AIR TOOL ACCESSORIES (HOSES & COUPLERS)

Chicago Pneum	Parker
Duro Reels	Reelcraft
Lincoln	Truflate

## BATTERY CHARGERS & TESTERS

Associated  
Auto Meter  
K & K

## BENCH GRINDERS

Baldor Wilton

## BRAKE WASHERS

R & D

## DIESEL STARTERS

R & D

## DIESEL SHOP TOOLS

OTC  
Proto

## HAND TOOLS

Craftsman	Proto
OTC	Ridgid

## HOISTS

Chicago Pneumatic  
Coffing (Duff Norton)  
Jet

## HYDRAULIC HOSES & COUPLERS

Blackhawk	OTC
Enerpac	Omega
Hein Werner	Pioneer

## HYDRAULIC RAMS

Blackhawk	Omega
Enerpac	Power Team
Hein Werner	Ram Pac
IMT	Simplex
OTC	

## IMPACT SOCKETS

Astro	Omega
Chicago Pneum	Ozat
Grey	Proto

## JACKS - AIR & HYDRAULIC

Astro	Norco
Ausco	OTC
Blackhawk	Omega
Chicago Pneum	Power Team
Enerpac	Ram Pac
Grey	Simplex
Hein Werner	Sunnex
IMT	Walker
Intermarket	Weaver
Lincoln	

## LUBRICATION EQUIPMENT

Aro	Grover
Alemite	Lincoln
Balcrank	Simpson
Graco	

## MECHANICS TOOL SET

Craftsman

## PALLET JACKS

Boman  
Pallet Mule

## PARTS WASHERS

Fountain

## PIPE TOOLS

Proto  
Ridgid

## PRESSES

Dake	Norco
Enerpac	OTC
Lincoln	Omega

## PRESSURE WASHERS

Jenny

## PULLERS

Blackhawk	OTC
Chicago Rawhide	Proto
J & J	Tiger

## REELS (AIR - LUBE - WATER)

Aro	Grover
Alemite	Lincoln
Balcrank	Reelcraft
Duro	Sampson
Graco	

## REFRIGERATION SERVICE EQUIP.

Robinair

## TIRE TOOLS & EQUIPMENT

B & J	Gaither Tools
Branick	Hendrix
Cheetah	IMT
Chicago Pneum	M-B Ind
Coats/Ammo	Mov-It Tire
Evershot Brander	No-Mar Rim Guard
Hennessy/Coats	Rema Regroovers
KenTool	TNT-100

## TIRE STORAGE RACKS

Kee Klamp  
Wesco

## TOOL CHESTS & SETS

Craftsman  
Enerpac  
Proto

## TORQUE WRENCHES

ATD	OTC
Proto	X-4

## VICES

Columbian  
Wilton

## WASHERS - BRAKE & PARTS

Fountain

## WELDING

Miller

## WHEEL CHOCKS

Durable

## CALL FOR SPARE PARTS

# INDUSTRIAL • MANUFACTURING • CONSTRUCTION

We can handle the entire job from tool selection to professional advice on the right tool for the job... it's faster, it costs less, and you have our professional reputation to back it up!

## AIR TOOLS



Impact Wrenches • Grinders • Screwdrivers  
• Nutrunners • Hammers • Paving Breakers  
• Rock Drills • Hoists • Compression Riveters  
• Drills • Tampers • Winches



Pumps • Cylinders • Presses • Nut Splitters  
• Pullers • Cable Cutters • Knockout Punches

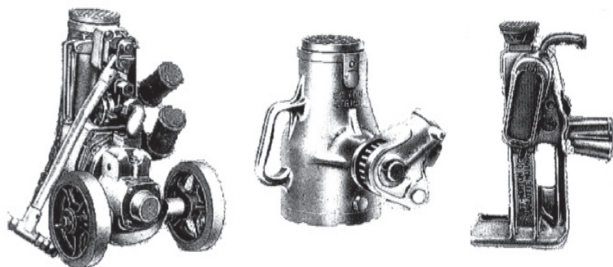

Air / Hyd. • Mech. • Journal • Jacks

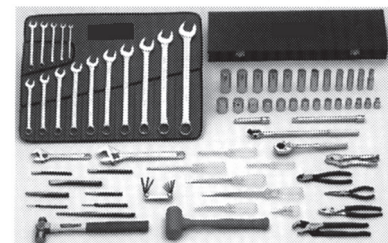

Professional Tools • Sockets • Torque  
Wrenches • Made in the U.S.A.

*You can say "goodbye" to your Industrial Tool & Equipment problems!*





**Attn: Shop Manager**

Thank you for reviewing our catalog.

Wesbrooks, Inc. has established a reputation with some of the leading Service Shops throughout the U.S.A. as a provider of tools & equipment.

In the development of new facilities, we can work with your architect on the design layout of a complete lubrication system, air compressor and shop tools.

Our success with your industry is a result of our commitment to not only sell equipment but to back up the sale with service after the sale.

Our 50 years of experience in the equipment business guarantees you quality equipment for 24 hour operation.

If you need descriptive product catalogs or would like to speak to our sales representative call us at 800.772.0863 or email [tools@wesbrooksinc.com](mailto:tools@wesbrooksinc.com).

**Mike Grauerholz**  
**President**

**P.S. See our website for more information • [www.wesbrooksinc.com](http://www.wesbrooksinc.com)**

**“For Quality Equipment with Service to back it up”**



2012 Sheppard Access Rd.  
Wichita Falls, TX 76306

ATTN: Shop Manager

TO:

**A, B, C**

**G, H, I, J**

Air Conditioner Equip	20
Air Hose	5,17,18
Air Line Couplers, Nipples	5
Air Line Filters	5,16
Air Line Lubricators	5,16
Air Line Regulators	5,16
Air Tool Accessories	5
Air Tool Grease, Oil	5
Air Tools	4
Battery Chargers	19
Battery Testers	19
Bead Seating Systems	10,11
Brake Washer	20
Breakers, Bead	11
Buffers, Tire	13
Cages, Tire Inflation	10
Cart, 55 gal. Drum	15
Chargers, Battery	19
Chocks, Wheel	12
Chucks, Air Tire	18
Clutch Adj. Tool	7
Clutch Align. Tools	7
Compressors, Air	5, 13
Couplers, Air	5
Cranes	8
Cylinders, Hydraulic	11

Gauge, Tire	18
Grinders, Bench	19
Hammers, Tire Repair	10
Hose, Air	5,17,18
Hose, Reel Replacement	17,18
Inflator Gauge, Tire	18
Jack Extensions	9
Jack, Pallet	8
Jacks, Rebuilt Air/Hyd	9
Jack Stands	9
Jack Stands, Air	9
Jack Stands, Steering Axle	12
Jacks, Air Lift	8,9
Jacks, Air/Hyd	4,9
Jacks, Exchange	2,3
Jacks, Hoist	8
Jacks, Floor	8
Jacks, Hand	8
Jacks, Transmission	8,9

Parts Washer	20	Tire Demount Tool	13
Pliers, Oil Filter	19	Tire Lift, Back Saver	12
Pliers, Lug Nut	10	Tire Platform	12,19
Pliers, Wheel Weight	10	Tire Spreaders	12
Porto Power Sets	8	Tire Storage Racks	12
Presses, Hydraulic	8	Tire Tools	10,11,13
Puller, U-joint	7	Tool Chests	14
Pump Exchange, Oil	3	Tools, Budd Nut	10
Pump Exchange, Grease	3	Tools, Industrial	22
Pumps, Air/Hydraulic	11	Tools, Tire Repair	10
Pumps, Diaphragm	15,17	Tool Set, Technician	14
Pumps, Grease & Oil	15,16	Torque Wrenches	7,12
Pumps, Transfer	15	U-Joint Pullers	7
Pumps, Waste Oil	15,17	Vises, Bench	19
Reels, Hose	17,18	Washers, Brake	20
Refrigerant Recovery	20	Washers, Parts	20
Regulators, Air Line	5,16	Waste Oil Drains, Pumps	15,17
Rim Guard, No-Mar	11	Welding Equip.	20

**D, E, F**

**K, L, M, N**

**S, T, U, V, W**

Dolly, Brake Drum	19
Drum Cart	15
Electronic Oil Meter	16
Electronic Oil Meter Exchange	3,16
Exchange Tools	2,3
Faucet, Radiator	18
Filters, Air Line	5,16

Leak Detector, A/C	20
Load Tester, Battery	19
Lubrication Equip.	15,16,17,18
Lubricators, Air Line	5,16
Mechanics Tool Set	14
Murphy's Soap	13

Socket Set, Pinion Nut	7	Wheel Seal Puller	12
Socket Sets	6	Wrenches, Air Exchange	2
Sockets - 1/2" drive	6	Wrenches, Oil Filter	19
Sockets - 3/4" drive	6	Wrenches, Torque	7,12
Sockets - 1" drive	6	Wrenches, Wheel Nut	7
Sockets - #5 spl. drive	6		
Sprayer, Sure Shot	11		
Spreaders, Tire	12		
Stands, Jack	9		
Starter, Diesel	19		
Stud Removers	10		
Testers, Battery	19		
Tire Balancers, Access.	13		
Tire Buffers	13		
Tire Changers, Access.	13		

**O, P, Q, R**

Oil, Compressor	5
Oil Meter	15,16
Oil Meter, Electronic	16
Oil Meter Exchange	3
Oil, Jack	9
Pallet Jack	8



**Call for Current Pricing**